

FLAPPER-TYPE VALVES

337-365-4411

sales@k-e-t.com

MODEL

G

FLAPPER TYPE-STANDARD

The Model G is a flapper-type float valve that, when opened, offers an unobstructed bore through the float valve. The uniquely designed flapper closes rapidly to prevent shavings from entering the drill string when circulation stops and also assists primary BOP equipment in maintaining internal pressure control. The valve will fully open when the first joint is raised from the hole, preventing pulling wet joints.

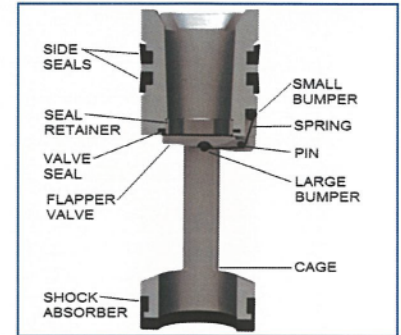

MODEL

GA

FLAPPER TYPE-PRESSURE MONITORING

The Model GA Pressure-Monitoring flapper-type float valve is indistinguishable from the Model G with the exception of a tungsten-carbide insert in the flapper valve. The insert has a quarter-inch orifice through the center that allows for differential pressure monitoring. The orifice also allows for partial automatic filling of the drill pipe during run in.

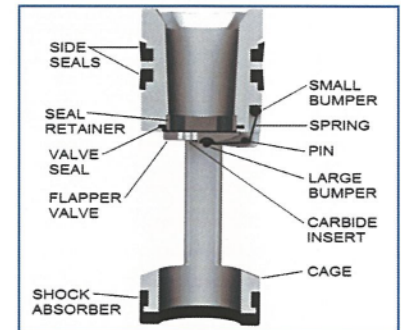

MODEL

GC

FLAPPER TYPE-AUTOMATIC FILL

The Model GC Automatic-Fill flapper-type float valve incorporates a unique self-releasing key assembly that holds the flapper partially open during run in, allowing the pipe to fill from the bottom. This eliminates the need for filling the drill pipe from the top, saving time and money. The valve will fully open when the first joint is raised from the hole, preventing pulling wet joints while avoiding the environmental and safety risks related to having mud on the rig floor. The valve can be run with the automatic-fill option or in the standard, closed position.

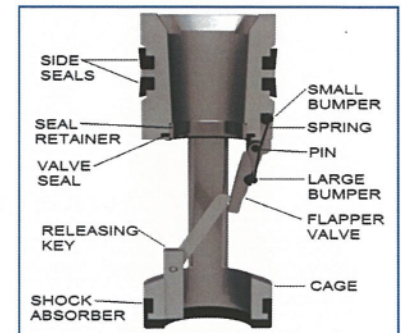

MODEL

GCA

FLAPPER TYPE-AUTO FILL PRESSURE MONITORING

The Model GCA Automatic-Fill/Pressure-Monitoring flapper-type float valve includes all the advantages of the Models G, GC, and GA. An unobstructed bore through the float valve, when open, permits automatic partial filling of the drill pipe from the bottom and measuring differential pressures when necessary.

